

PRIMARY CHANNEL DRYWALL SUSPENSION

PC1238-060

Primary Channel	Depth	Width	Thickness
-----------------	-------	-------	-----------

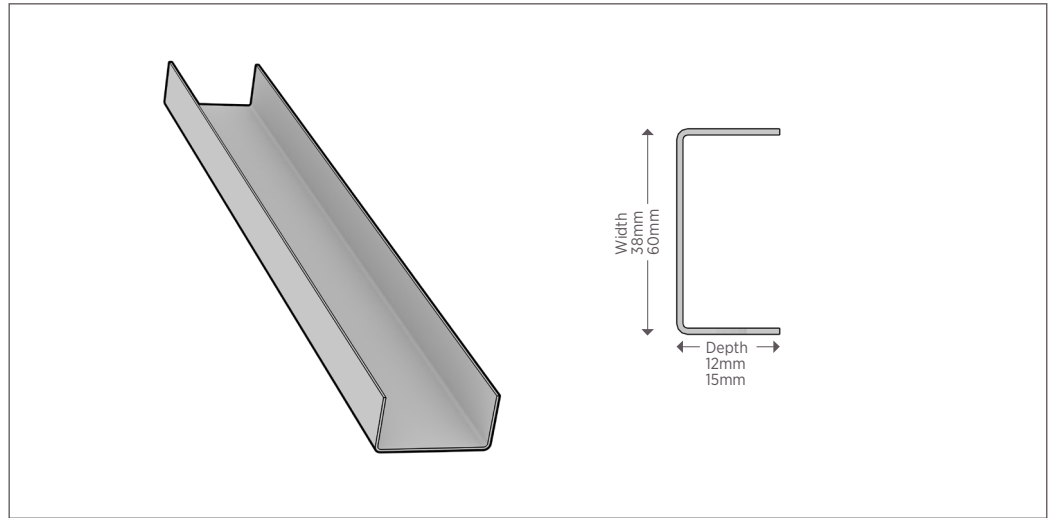

DESCRIPTION

- Used as main carrying channels in the Drywall Ceiling suspension systems where it is suspended from the overhead structure using different types of hangers and suspension accessories.
- It also forms along with the perimeter angles a solid horizontal bridging to resist rotation and axial loads.
- Optional used as suspension hangers.

SECTION & MATERIAL PROPERTIES

Type	Thickness (mm)	Depth (mm)	Width (mm)	Section Area (mm ²)	Centroid (mm)	Moment of inertia (Ixx)(mm ⁴)	Section Modulus (Sx)(mm ³)	Steel Mechanical Properties		
								Yield Strength N/mm ²	Tensile Strength N/mm ²	Elongation (%)
Primary or Carrying Channels	0.50	12 / 12	38	29.0	19	6,505.33	342.39	297-308	366-372	29-30
	0.55	12 / 12		31.9	19	7,143.56	375.97	297-308	366-372	29-30
	0.60	12 / 12		34.8	19	7,779.57	409.45	297-308	366-372	29-30
	0.70	12 / 12		40.6	19	9,044.97	476.05	297-308	366-372	30-31
	0.80	12 / 12		46.4	19	10,301.60	542.19	297-308	366-372	30-31
	0.90	12 / 12		52.2	19	11,549.50	607.87	297-308	366-372	30-31
	1.00	12 / 12		58.0	19	12,788.67	673.08	297-308	366-372	30-31
	1.20	12 / 12		69.6	19	15,241.18	802.16	297-308	366-372	30-31
	1.50	12 / 12		87.0	19	18,856.00	992.42	297-308	366-372	31-32
	0.50	15 / 15	60	45.0	30	22,276.25	742.54	297-308	366-372	29-30
	0.55	15 / 15		49.5	30	24,479.40	815.98	297-308	366-372	29-30
	0.60	15 / 15		54.0	30	26,678.16	889.27	297-308	366-372	29-30
	0.70	15 / 15		63.0	30	31,062.00	1,035.41	297-308	366-372	30-31
	0.80	15 / 15		72.0	30	35,429.12	1,180.97	297-308	366-372	30-31
	0.90	15 / 15		81.0	30	39,778.30	1,325.95	297-308	366-372	30-31
	1.00	15 / 15		90.0	30	44,110.00	1,470.35	297-308	366-372	30-31
	1.20	15 / 15		108.0	30	52,721.30	1,757.38	297-308	366-372	30-31
	1.50	15 / 15		135.0	30	65,508.75	2,183.63	297-308	366-372	31-32

PACKAGING

	Primary Channel - Drywall Suspension
0.45mm - 1.5mm	Bundle of 800 PCS

MATERIAL PROPERTIES

Yield stress, Fy 33 ksi Ultimate, with G40-G90 Zinc coating

ASTM & CODE STANDARDS

- Primary Channels are produced to meet ASTM C645 and C955
- Galvanized sheet steel meets requirements of ASTM A-653
- For installation & storage information refer to ASTM C1007 & C754

GREEN BENEFITS AND RECYCLED CONTENT

- LEED Credit MR 2 – USG products are manufactured from cold formed steel. Steel is 100% recyclable, which helps divert debris from the waste stream.
- LEED Credit MR 4 – USG’s steel products have a minimum of 25.5% post-consumer recycled content, and 6.8% pre-consumer.

REFERENCES

For further health and safety instructions, refer to the Safety Data Sheet (SDS) for this product, available from your USG Middle East sales office or **USGme.com**

Disclaimer:

Information contained in this document is subject to change without prior notice due to our ongoing product development. We recommend referring to the website **usgme.com** for the most up-to-date and accurate product information.

©2024 Factory of USG Middle East LTD. Co. All rights reserved.

