

WEDGE ANCHOR

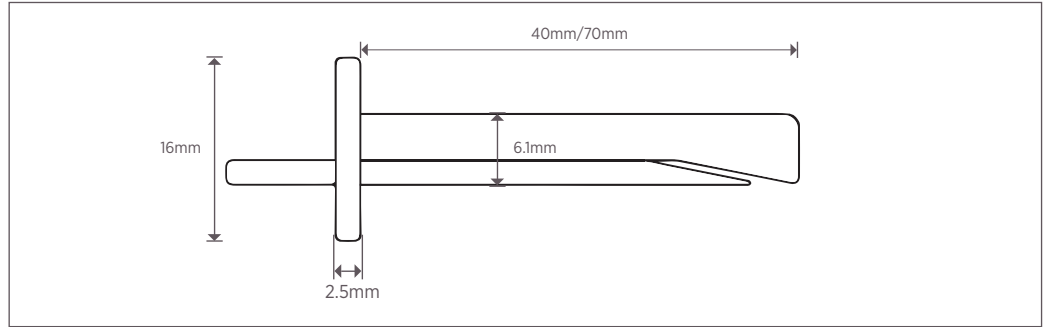

DESCRIPTION

Wedge Anchor designed for the USG ME systems installation. Ideal for ceiling perimeter installations and partition construction necessitating fire resistance, the Wedge Anchor excels. Its applicability extends to both cracked and un-cracked concrete, in addition to natural stone and solid block surfaces, ensuring adaptability across various applications.

- Fire Rated Solutions
- Fast & Easy to apply
- Applicable for ceilings, perimeter fixings and fire-resistant Partition systems

PRODUCT DATA

Finish: Zinc Electro-plated minimum 5 um I according to EN-12329

Property	TCABZP6X40MM	TCABZP6X70MM
Length	40mm	70mm
Drill hole diameter	6mm	6mm
Drill hole depth	40mm	40mm
Effective embedment	32mm	32mm
Diameter of hole in fixture	7mm	7mm
Maximum fixture thickness	5mm	35mm
Minimum anchor spacing	150mm	150mm
Minimum edge distance	100mm	100mm
Minimum concrete thickness	80mm	80mm

PULL OUT LOADS

Property	TCABZP6X40MM	TCABZP6X70MM
Recommended Load, any direction	2.4kN	2.4kN
Recommended bending resistance	2.7N-m	2.7N-m

Loads in concrete C20/25

REFERENCES

For further health and safety instructions, refer to the Safety Data Sheet (SDS) for this product, available from your USG Middle East sales office or USGme.com

Disclaimer:

Information contained in this document is subject to change without prior notice due to our ongoing product development. We recommend referring to the website usgme.com for the most up-to-date and accurate product information.

©2024 Factory of USG Middle East LTD. Co. All rights reserved.



Wedge Anchor

Version #: 01 / Revision date: - / Issue date: 10-January-2024 / Doc. Ref. MF-TDS047-1-UAE

This technical datasheet is specifically intended for use in the market supplied by USG ME United Arab Emirates (BMET).